

PATRIOT

Radiant Gas Countertop Charbroiler

FMECTC-24/NG
FMECTC-36/NG
FMECTC-48/NG

Patriot's radiant gas countertop charbroilers

are designed for use with either natural or LP gas. Constructed of a stainless steel front with galvanized sides. These units are able to stand the toughest of kitchen environments. Each unit includes tips for field conversion to LPG.



FMECTC-48/NG

Standard Features

- Stainless steel front bullnose design with galvanized sides
- Fully welded stainless steel backsplash for extra durability
- 30,000 BTU per burner
- One stainless steel burner every 12" grate width
- Cast iron grill grates are reversible and height adjustable
- 4"-5" adjustable legs
- Separate gas valves for each burner with standing pilot ignition system
- Removable stainless steel drip tray for easy cleaning
- 3/4" rear NPT gas inlet
- ETL Listed and ETL Sanitation

Specifications



Model	Overall Width	Burners	Total BTU	Net Weight	Gross Weight
FMECTC-24/NG	24"	2	60,000	119 lbs	154 lbs
FMECTC-36/NG	36"	3	90,000	163 lbs	218 lbs
FMECTC-48/NG	48"	4	120,000	244 lbs	359 lbs

PATRIOT

Radiant Gas Countertop Charbroiler

FMECTC-24/NG, FMECTC-36/NG, FMECTC-48/NG

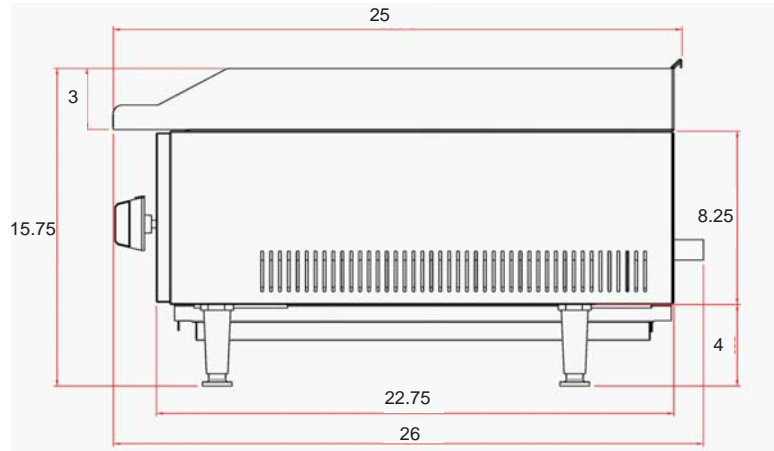
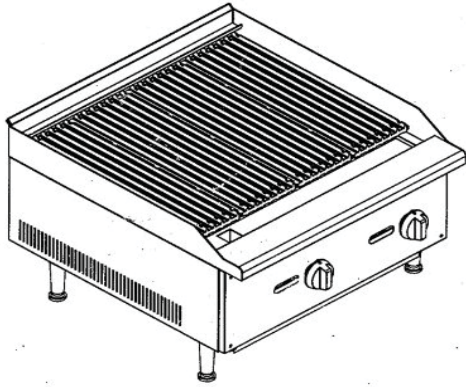

Unit Dimensions (inches)

Model	Description	Width	Depth	Height
FMECTC-24/NG	24" Charbroiler	24	26	15.75
FMECTC-36/NG	36" Charbroiler	36	26	15.75
FMECTC-48/NG	48" Charbroiler	48	26	15.75

Drip Tray (inches)

Model	Width	Depth	Height	Drip Tray Qty
FMECTC-24/NG	20.75	20.75	1	1
FMECTC-36/NG	31.5	20.75	1	1
FMECTC-48/NG	20	20.75	1.25	2

Warranty

Patriot warrants this product to be free of defects in materials and workmanship for a period of 3 years from the date of original installation.