



FM-90
FM-120

FM-150

FM-90, FM-120, FM-150 Economy Tube Fired Gas Fryers

Standard Specifications

CONSTRUCTION

- Welded 16 gauge stainless steel tank with a super smooth machine finish ensures easy cleaning
- Long lasting baffles are mounted in the heat exchange tubes to provide maximum heating and combustion efficiency
- Standing pilot light design provides a ready flame when heat is required
- Cabinet is constructed of stainless steel front and door with galvanized sides and back

STANDARD ACCESSORIES

- Two nickel plated oblong wire mesh baskets
- One nickel plated tube rack
- One drain extension
- 6" Casters

OPERATIONS

- Standing pilot and thermostat maintain temperature automatically at the selected temperature (between 200°F(93°C) and 400°F (204°C))
- Front 1-1/4" drain, for quick draining

AVAILABLE OPTIONS & ACCESSORIES

- Stainless steel cover
FM-90, FM-120 cover # 419101
FM-150 cover # 419102

CONTROLS

- Thermostat maintains temperature between 200°(93°C) and 400°F(204°C)
- Integrated gas control valve acts as a manual and pilot valve, automatic pilot valve, gas filter, pressure regulator and automatic main valve
- Gas control valve prevents gas flow to the main burner until pilot is established and shuts off all the gas flow automatically if the pilot flame goes out
- Temperature limit automatically shuts off all gas flow if the fryer temperature exceeds 450°F(232°C)

WARRANTY

Patriot warrants to the original user of its FM series gas fryers and related equipment that said appliances and related equipment will be free from defects in material and workmanship under normal use for a period of three (3) years from the date of installation, with appropriate documentation. Should your equipment fail within this time, upon approval, parts and labor charges will be covered by this warranty. The Stainless steel fry tank has a five (5) year limited tank warranty. If during the first year only, the tank is found to have a leak and is verified by an authorized service company, the entire fryer will be replaced. After the first year a replacement tank will be sent free of charge excluding freight and labor charges.

APPROVALS

- ETL Approved
- ETL Sanitation
- AGA Certified



PATRIOT

The installer of this unit should be aware of state, county or local code for connecting this equipment to determine if an external regulator is required

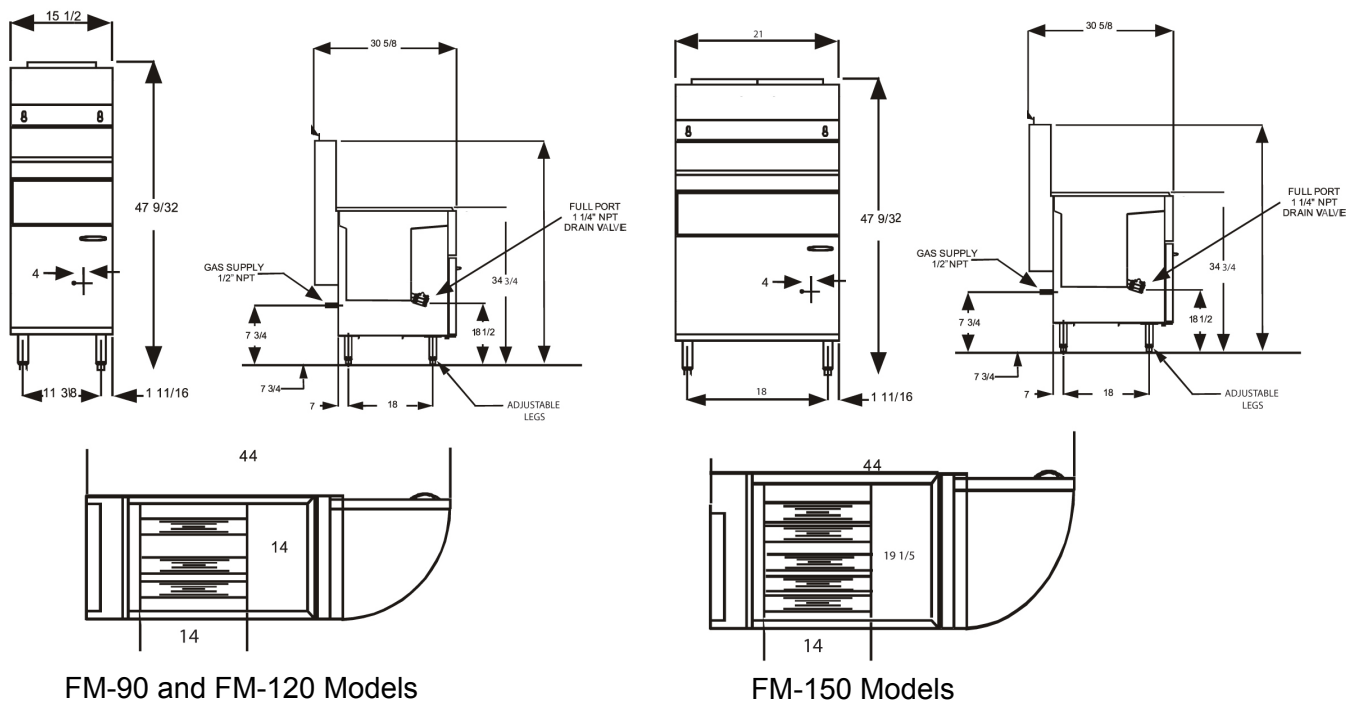

FM-90 and FM-120 Models

FM-150 Models

Specifications

Model Number	BTU	Net Weight (lb)	Gross Weight (lb)	Oil Capacity (lb)
FM-90/NG	90,000	152 (69kg)	169 (77kg)	35-40 (18.5-23 L)
FM-90/LPG	90,000	152 (69kg)	169 (77kg)	35-40 (18.5-23 L)
FM-120/NG	120,000	163 (74kg)	180 (82kg)	45-50 (21.3-25 L)
FM-120/LPG	120,000	163 (74kg)	180 (82kg)	45-50 (21.3-25 L)
FM-150/NG	150,000	198.5 (90kg)	218 (99kg)	65-70 (31-37 L)
FM-150/LPG	150,000	198.5 (90kg)	218 (99kg)	65-70 (31-37 L)

Shipping Info

Model Number	Cubic Feet	Dimensions (in)
FM-90/NG	15.9 (0.45 cubic meters)	45”H x 15 1/2”W x 30 1/4”D
FM-90/LPG	15.9 (0.45 cubic meters)	45”H x 15 1/2”W x 30 1/4”D
FM-120/NG	15.9 (0.45 cubic meters)	45”H x 15 1/2”W x 30 1/4”D
FM-120/LPG	15.9 (0.45 cubic meters)	45”H x 15 1/2”W x 30 1/4”D
FM-150/NG	20.5 (0.58 cubic meters)	45”H x 21”W x 30 1/4”D
FM-150/LPG	20.5 (0.58 cubic meters)	45H x 21”W x 30 1/4”D

